



Series Sensitive Gate SCRs

Description

The SCRs series provide high dv/dt rate with strong resistance to electromagnetic interference. They are especially recommended for use on residual current circuit breaker, straight hair, igniter etc.

Mechanical data

- Case: TO-251W
- Approx. Weight: 0.342g (0.012oz)
- Case: TO-252W
- Approx. Weight: 0.329g (0.011oz)
- Lead free finish, RoHS compliant
- Case Material: "Green" molding compound, UL flammability classification 94V-0, "Halogen-free".

TO-251W(Suffix:V)

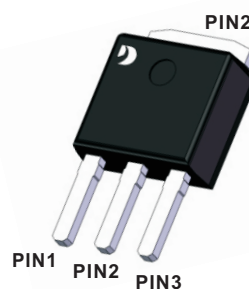

TO-252W(Suffix:D)

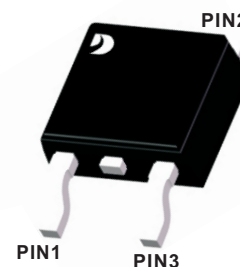

Application Circuit

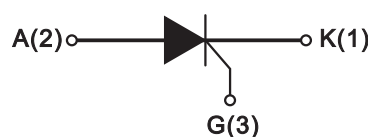

■ Absolute Maximum Ratings (Operating temperature range applies unless otherwise specified)

Parameter	Symbols	Ratings	Unit
Repetitive peak off-state voltage	V _{DRM}	600	V
Repetitive peak reverse voltage	V _{RRM}	600	V
RMS on-state current	I _{T(RMS)}	2	A
Non repetitive surge peak on-state current (f=50Hz, tp=10ms)	I _{TSM}	20	A
I ² t value for fusing (tp=10ms)	I ² T	2	A ² S
Critical rate of rise of on-state current	di/dt	50	A/us
Peak gate current (tp=20μs, Tj=125°C)	I _{GM}	0.2	A
Peak gate power (tp=20μs, Tj=125°C)	P _{GM}	0.5	W
Average gate power dissipation(Tj=125°C)	P _{G(AV)}	0.1	W
Operating junction temperature range	T _J	-40 to +125	°C
Storage junction temperature range	T _{STG}	-40 to +150	°C

NOTE 1: When we parallel connect a ≤1KΩ resistor between Gate and Cathode, the T_J can reach 125°C; if without this resistor, the T_J only can reach 110°C.



■ Electrical Characteristics (T_J=25°C Unless Otherwise Specified)

Symbols	Test Condition	Min	Typ	Max	Unit
I _{GT}	V _D =12V R _L =33Ω		50	200	uA
V _{GT}			0.6	0.8	V
V _{GD}	V _D =V _{DRM} T _J =125°C	0.2			V
I _L	I _G =1.2 I _{GT}			6	mA
I _H	I _T =0.05A			5	mA
dV/dt	V _D =400V T _J =125°C R _{GK} =1KΩ	60			V/us
	V _D =400V T _J =125°C R _{GK} =220Ω	500			
R _D	Dynamic Resistance T _J =125°C			180	mΩ

■ Static Characteristics

Symbols	Parameter		Value(Max)	Unit
V _{TM}	I _T =4A t _p =380μs	T _J =25°C	1.5	V
I _{DRM}	V _D =V _{DRM} V _R =V _R RM	T _J =25°C	5	uA
I _{RRM}		T _J =125°C	100	uA

■ Thermal Resistances

Symbols	Parameter		Value(Max)	Unit
R _{th(j-c)}	junction to case	TO-251W TO-252W	6.5	°C/W



TO-251W(I-PAK) Package Outline Dimensions

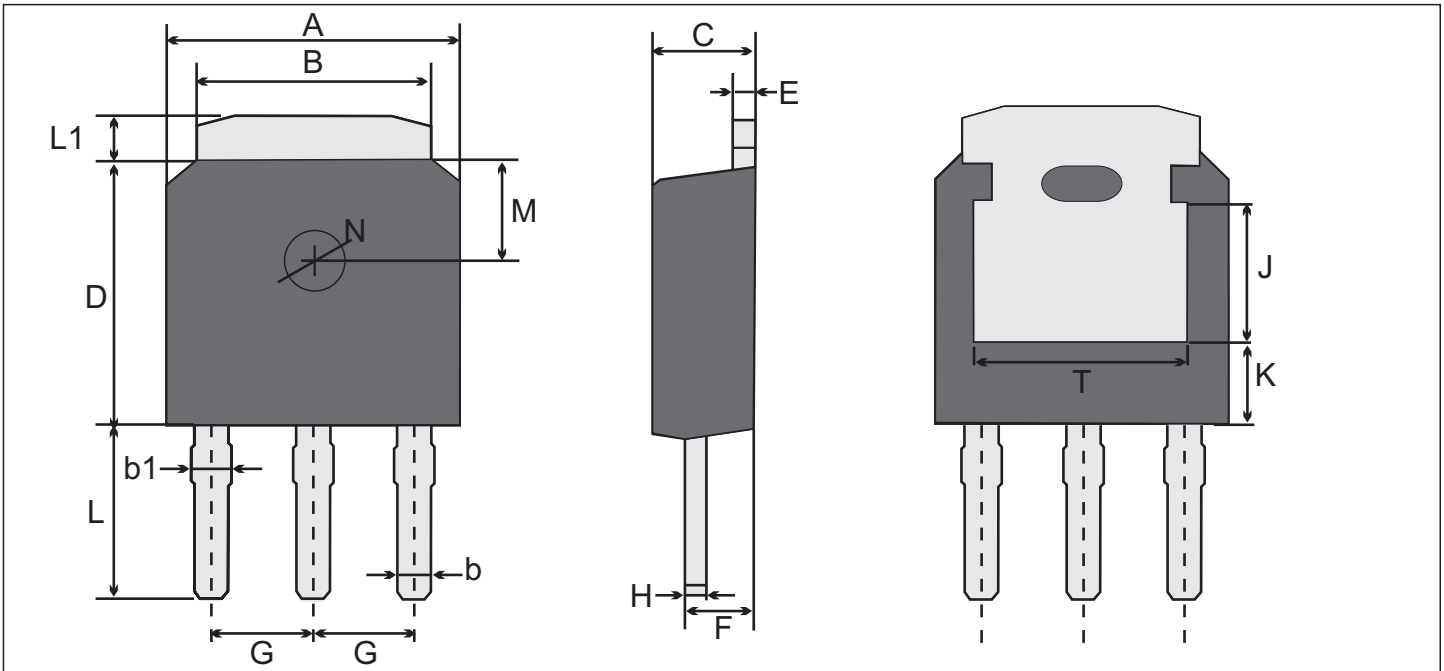

TO-251W(I-PAK) mechanical data

UNIT	A	B	b	b1	C	D	E	F	G	H	L	L1	M	N	J	T	K	
mm	max	6.7	5.53	0.86	1.11	2.5	6.3	0.61	1.72	2.3 typ.	0.56	4.3	1.2	1.8 typ.	1.3 typ.	3.2 ref.	4.83 ref.	1.8 ref.
	typ	6.6	5.33	0.76	0.91	2.3	6.1	0.51	1.52		0.51	4.1	1.0					
	min	6.3	5.13	0.66	0.71	2.1	5.9	0.41	1.32		0.46	3.9	0.8					
mil	max	264	218	34	44	98	248	24	68	91 typ.	22	169	47	71 typ.	51 typ.	126 ref.	190 ref.	71 ref.
	typ	260	210	30	36	91	240	20	60		20	161	39					
	min	248	202	26	28	83	232	16	52		18	154	31					

Marking Diagram

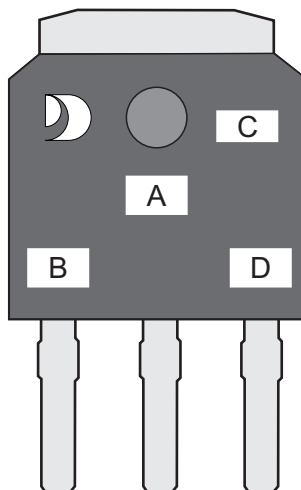

- Unmarkable Surfacea
- Marking Composition Field
- A: Marking Area
- B: Lot Code
- C: Additional Information
- D: Date Code (YWW)
- Y: Years(0~9)
- WW: Week



TO-252W(D-PAK) Package Outline Dimensions

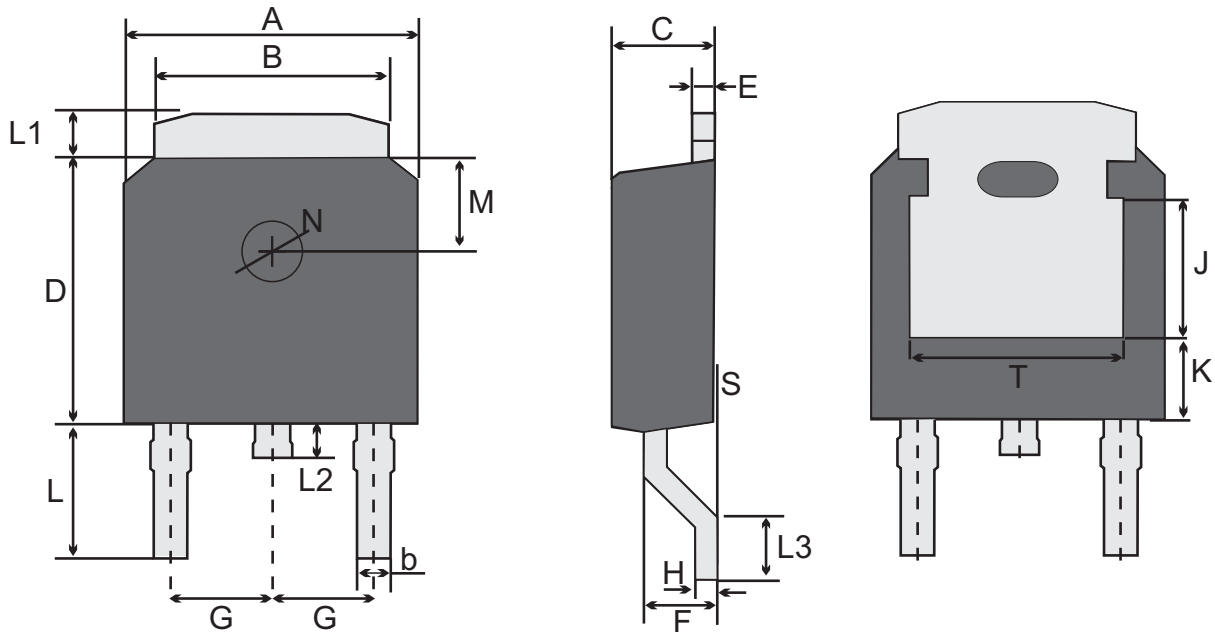

TO-252W(D-PAK)Mechanical data

UNIT		A	B	b	C	D	E	F	G	H	L	L1	L2	L3	S	M	N	J	T	K
mm	max	6.7	5.53	0.86	2.5	6.3	0.61	1.87	2.3 typ.	0.55	3.0	1.2	1.0	1.75	0.10	1.8 typ.	1.3 typ.	3.2 ref.	4.83 ref.	1.8 ref.
	typ	6.6	5.33	0.76	2.3	6.1	0.51	1.57		0.50	2.8	1.0	0.8	1.30	0.08					
	min	6.3	5.13	0.66	2.1	5.9	0.41	1.27		0.45	2.6	0.8	0.6	1.0	/					
mil	max	264	218	34	98	248	24	74	91 typ.	22	118	47	39	69	4	71 typ.	51 typ.	126 ref.	190 ref.	71 ref.
	typ	260	210	30	91	240	20	62		20	110	39	31	51	3					
	min	248	202	26	83	232	16	50		18	102	31	24	39	/					

Marking Diagram

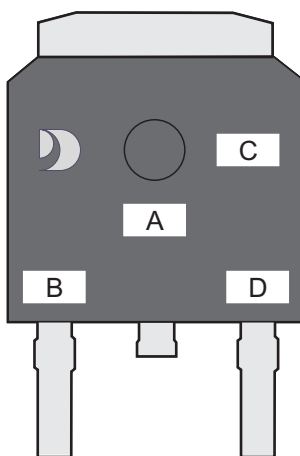

- Unmarkable Surfacea
- Marking Composition Field
- A: Marking Area
- B: Lot Code
- C: Additional Information
- D: Date Code (YWW)
- Y: Years(0~9)
- WW: Week



Important Notice and Disclaimer

Jingdao Microelectronics reserves the right to make changes to this document and its products and specifications at any time without notice. Customers should obtain and confirm the latest product information and specifications before final design, purchase or use.

Jingdao Microelectronics makes no warranty, representation or guarantee regarding the suitability of its products for any particular purpose, not does Jingdao Microelectronics assume any liability for application assistance or customer product design.

Jingdao Microelectronics does not warrant or accept any liability with products which are purchased or used for any unintended or unauthorized application.

No license is granted by implication or otherwise under any intellectual property rights of Jingdao Microelectronics.

Jingdao Microelectronics products are not authorized for use as critical components in life support devices or systems without express written approval of Jingdao Microelectronics.